

REVISION HISTORY			
REV	DESCRIPTION	DATE	APPROVED
AA	ISSUED FOR REVIEW	03/08/2016	XX

APPROVAL	
THIS DRAWING IS SUBMITTED FOR APPROVAL ONLY. THIS DRAWING IS NOT TO BE USED FOR CONSTRUCTION UNTIL APPROVED.	
CUSTOMER IS RESPONSIBLE FOR CONFIRMING THE DIMENSIONS AND GENERAL LAYOUT, NOTING ANY EXISTING CONDITIONS THAT MAY AFFECT THIS LAYOUT.	
<input type="checkbox"/> APPROVED AS DRAWN	<input type="checkbox"/> APPROVED AS NOTED
<input type="checkbox"/> REVISE AND RESUBMIT	
BY:	DATE:
TITLE:	
COMPANY:	

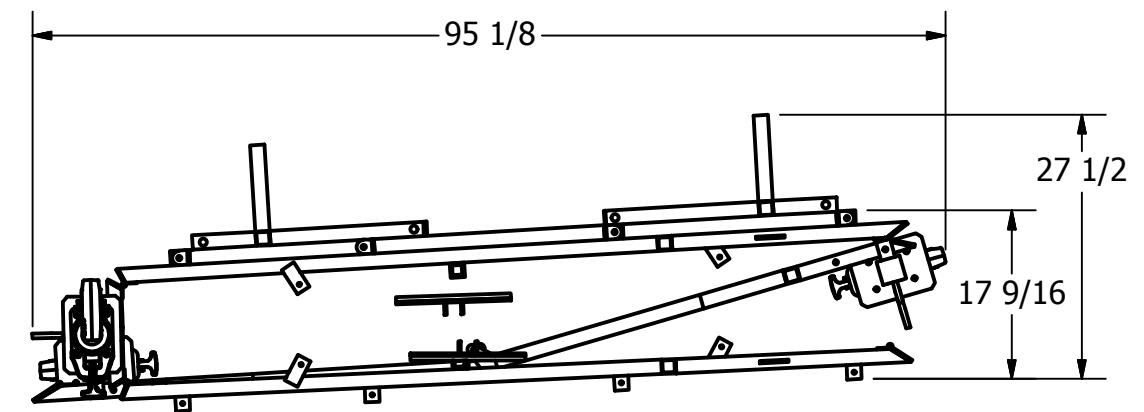

PAD HEIGHT
30 3/8
ADJUSTABLE TO
63 7/8

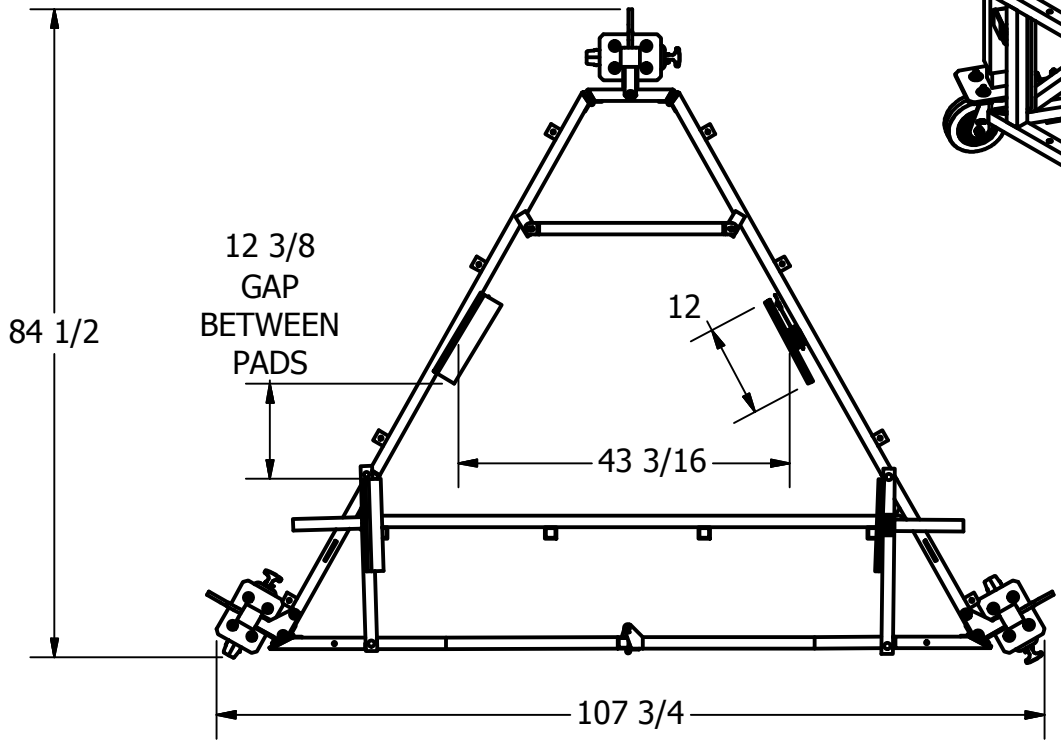
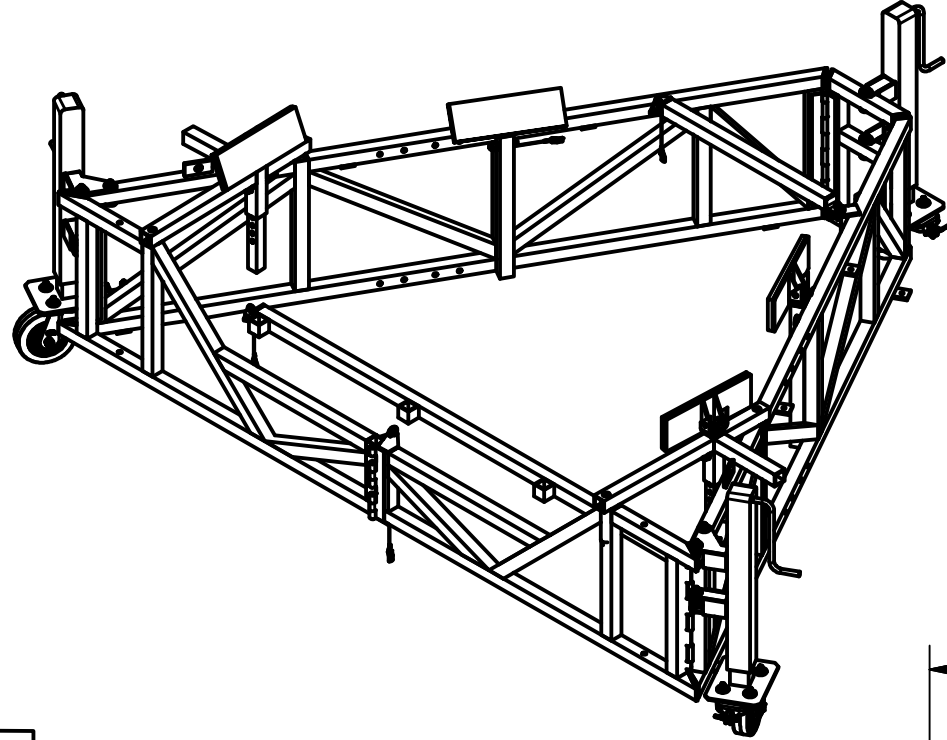
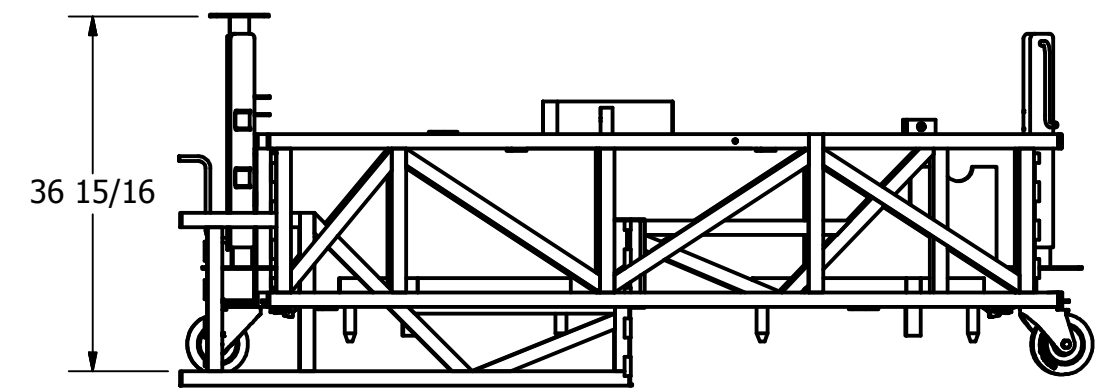
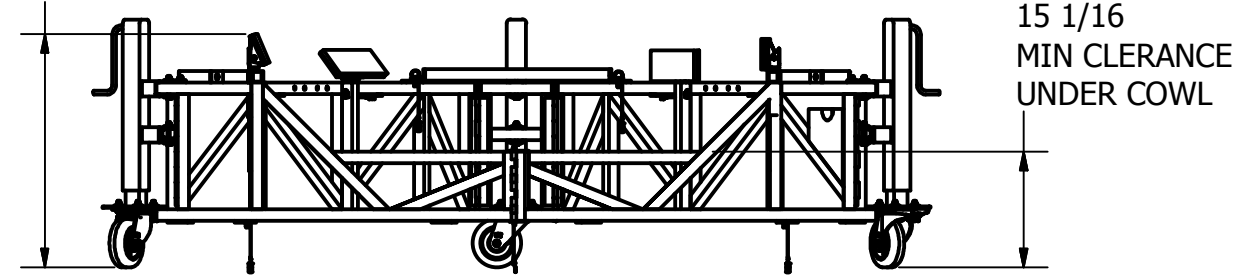

SHOWN COLLAPSED

GENERAL NOTES:

- 1) ALL STRUCTURAL STEEL SECTIONS SHALL CONFORM TO CSA G40.21-50W
- 2) ALL STEEL PLATE AND BAR SHALL CONFORM TO CSA G40.21-44W
- 3) ALL WELDING SHALL CONFORM TO CSA W59 AND BE UNDERTAKEN BY A WELDER FULLY APPROVED BY THE CANADIAN WELDING BUREAU TO CSA W47 DIVISION
- 4) ALL WELDS TO BE SMOOTH AND FREE OF BURRS
- 5) ALL WELDS TO BE 1/4" CONTINUOUS FILLET OR 1/4" EFFECTIVE THROAT FLARE BEVEL U.N.O.

THIS DRAWING AND THE INTELLECTUAL INFORMATION ON THIS DRAWING ARE THE PROPERTY OF LIFTSAFE ENGINEERING & SERVICE GROUP INC. AND MAY NOT BE REPRODUCED OR USED IN ANY MANNER WITHOUT OUR WRITTEN CONSENT

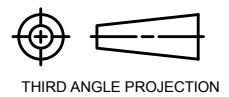

Tolerance Unless Noted Otherwise				
ANGLE	FRACTION	DECIMAL PLACES	INCHES	MILLIMETRES
± 1/2°	± 1/16	.XXX	± .005	± 0.1
		.XX	± .010	± 0.3
		.X	± .020	± 0.5

Part No. V02159		LIFTSAFE ENGINEERING & SERVICE GROUP INC.	
Materials.		www.liftsafeinspections.com T. (519) 896-2430/1-800-977-2005, Email: info@liftsafeinspections.com F. (519) 896-2085	
Work Order No.	Customer & Location: LFP	Project: NOSE COWL STAND <small>TARE WEIGHT: Weight</small>	
Next Assembly.	Checked By: R.B. Date: XX/XX/2016	Description:	
	Designed By: E.D. Date: 03/01/2016	SIZE: B	SCALE: N.T.S
	Drawn By: E.D. Date: 03/08/2016	DWG NO: DF071560-01	
		SHEET 1 OF 1	
			REV AA