

SIGNATURE	DATE
-----------	------

REVISION HISTORY			
REV	DESCRIPTION	DATE	APPROVED
6.1	ISSUED FOR PRODUCTION	1/21/2016	C.R.

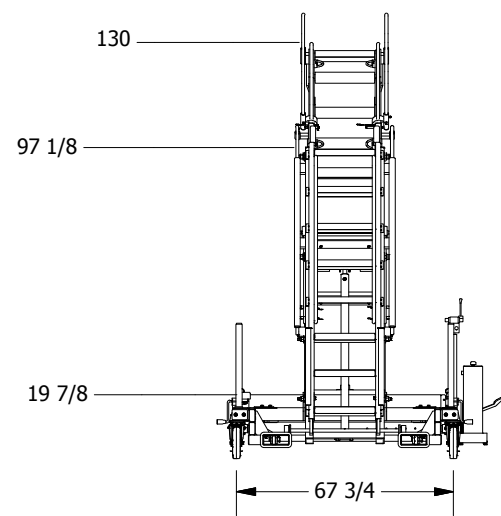

STAND @ 73° LADDER RETRACTED

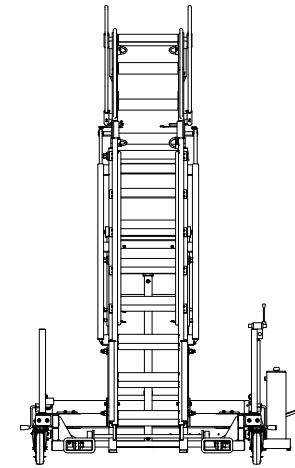
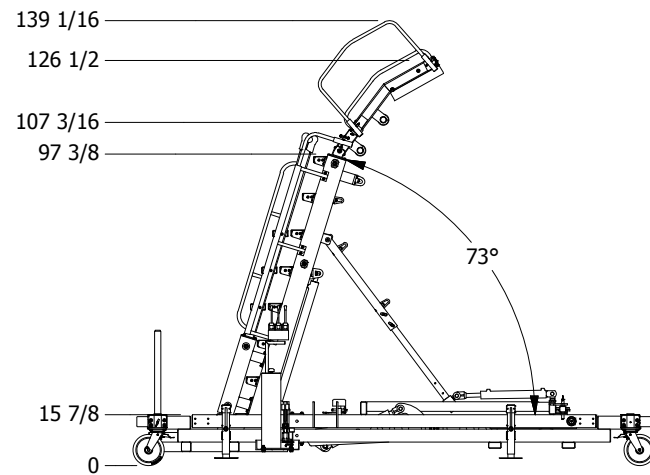

STAND @ 83° LADDER RETRACTED

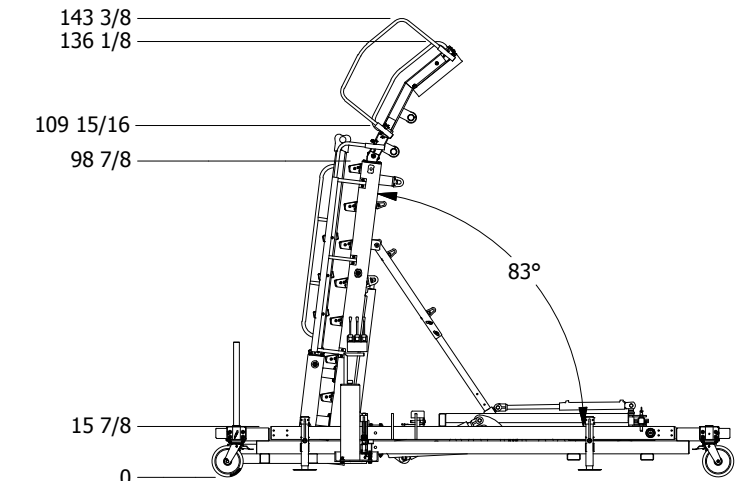

STAND @ 83° LADDER EXTENDED

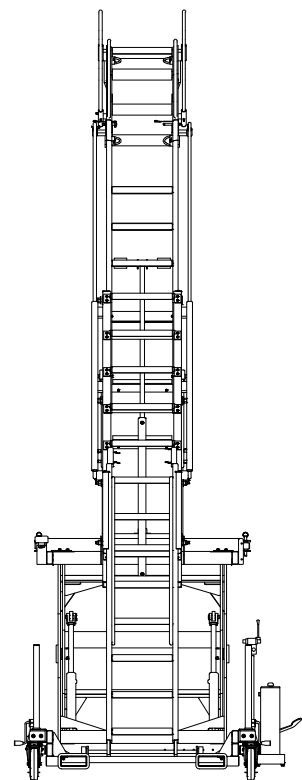

STAND @ 73° LADDER EXTENDED

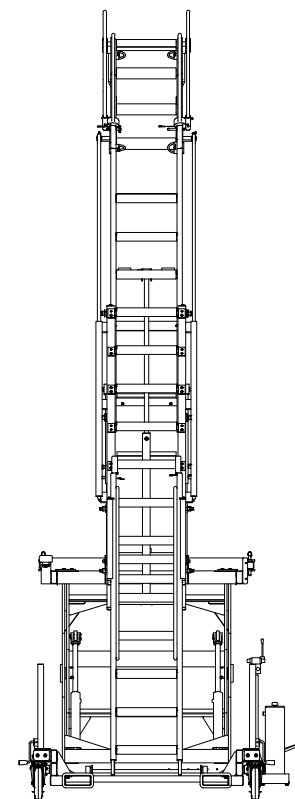
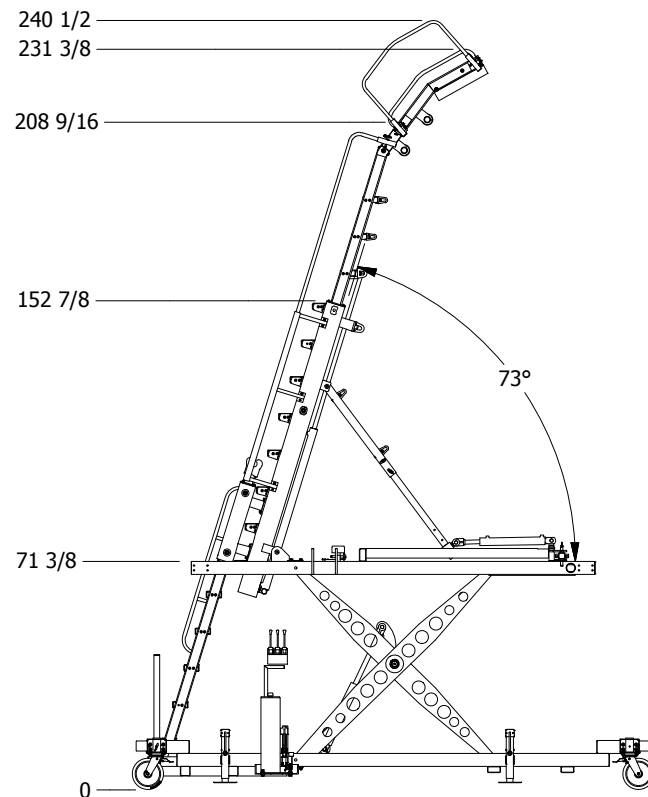

GENERAL NOTES:

- 1) ALL STRUCTURAL STEEL SECTIONS SHALL CONFORM TO CSA G40.21-50W
- 2) ALL STEEL PLATE AND BAR SHALL CONFORM TO CSA G40.21-44W
- 3) ALL WELDING SHALL CONFORM TO CSA W59 AND BE UNDERTAKEN BY A WELDER FULLY APPROVED BY THE CANADIAN WELDING BUREAU TO CSA W47 DIVISION
- 4) ALL WELDS TO BE SMOOTH AND FREE OF BURRS
- 5) ALL WELDS TO BE 1/4" CONTINUOUS FILLET OR 1/4" EFFECTIVE THROAT FLARE BEVEL U.N.O.

THIS DRAWING AND THE INTELLECTUAL INFORMATION ON THIS DRAWING ARE THE PROPERTY OF LIFTSAFE ENGINEERING & SERVICE GROUP INC. AND MAY NOT BE REPRODUCED OR USED IN ANY MANNER WITHOUT OUR WRITTEN CONSENT

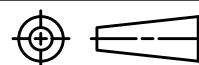

THIRD ANGLE PROJECTION

Tolerance Unless Noted Otherwise

ANGLE	FRACTION	DECIMAL PLACES	INCHES	MILLIMETRES
± 1/2°	± 1/16	.XXX	± .005	± 0.1
		.XX	± .010	± 0.3
		.X	± .020	± 0.5

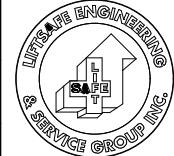
Part No. V00026		LIFTSAFE ENGINEERING & SERVICE GROUP INC.	
Materials. -----		www.liftsafeinspections.com T. (519) 896-2430/1-800-977-2005, Email: info@liftsafeinspections.com F. (519) 896-2085	
Work Order No.		Customer & Location:	Project:
Next Assembly.		ENG. ACCESS WITH SCISSOR	
Checked By: CR	Date: 1/21/2016	Description:	
Designed By: GR	Date: 1/21/2016	SIZE: B	SCALE: N.T.S.
Drawn By: GR	Date: 1/21/2016	SHEET 1 OF 1	
			DWG NO: DF071554-06
			REV: 6.1