

REVISION HISTORY			
REV	DESCRIPTION	DATE	APPROVED
0	ISSUED FOR PRODUCTION	01/01/2019	R.B.

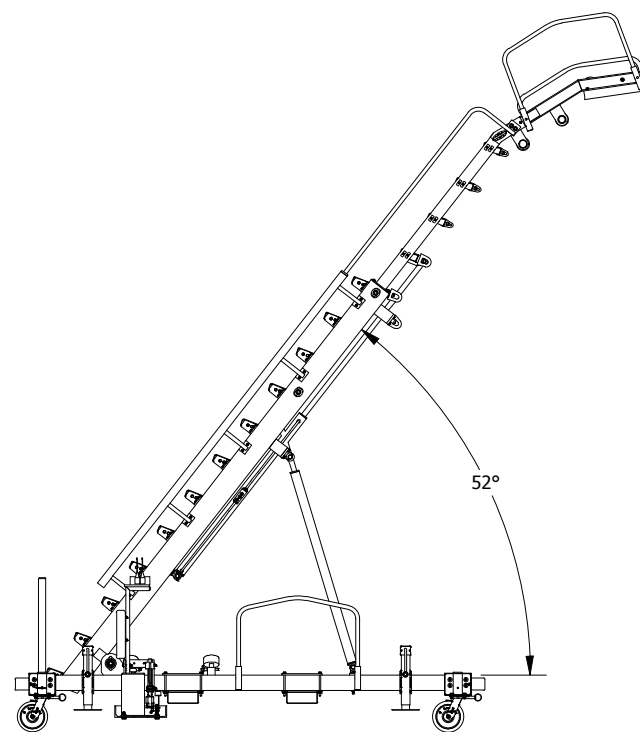
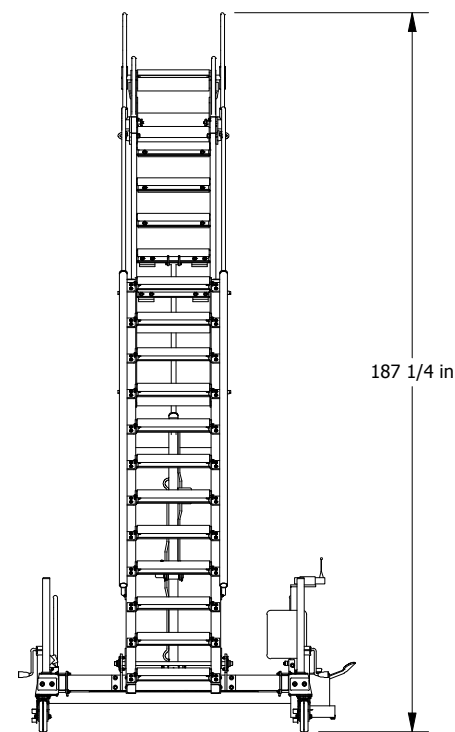
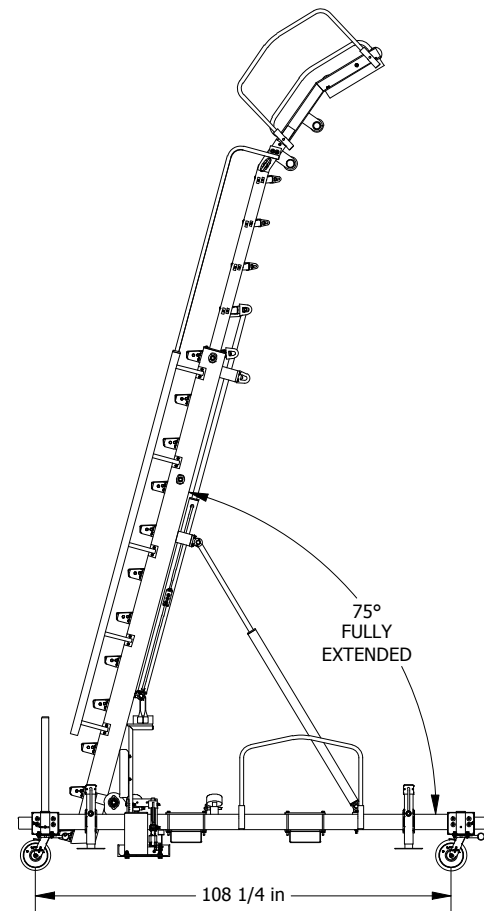
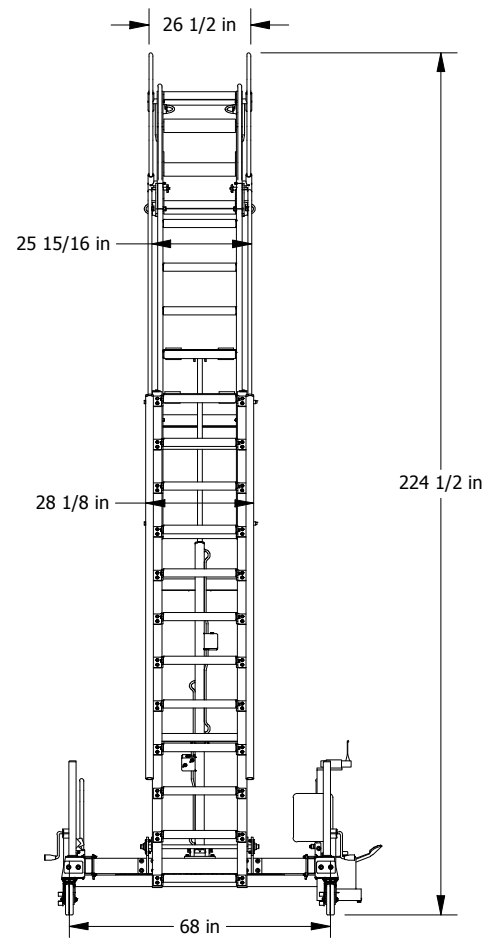

**GENERAL NOTES:**

- 1) ALL STRUCTURAL STEEL SECTIONS SHALL CONFORM TO CSA G40.21-50W
- 2) ALL STEEL PLATE AND BAR SHALL CONFORM TO CSA G40.21-44W
- 3) ALL WELDING SHALL CONFORM TO CSA W59 AND BE UNDERTAKEN BY A WELDER FULLY APPROVED BY THE CANADIAN WELDING BUREAU TO CSA W47 DIVISION
- 4) ALL WELDS TO BE SMOOTH AND FREE OF BURRS
- 5) ALL WELDS TO BE 1/4" CONTINUOUS FILLET OR 1/4" EFFECTIVE THROAT FLARE BEVEL U.N.O.

THIS DRAWING AND THE INTELLECTUAL INFORMATION ON THIS DRAWING ARE THE PROPERTY OF LIFTSAFE ENGINEERING & SERVICE GROUP INC. AND MAY NOT BE REPRODUCED OR USED IN ANY MANNER WITHOUT OUR WRITTEN CONSENT

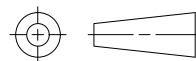

THIRD ANGLE PROJECTION

Tolerance Unless Noted Otherwise

ANGLE	FRACTION	DECIMAL PLACES	INCHES	MILLIMETRES
± 1/2"	± 1/16	.XXX	± .005	± 0.1
		.XX	± .010	± 0.3
		.X	± .020	± 0.5

Part No.

**V03772**

Materials.

Work Order No.

Next Assembly.

Checked By:

Designed By:

Drawn By:

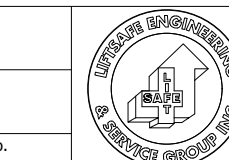

**LIFTSAFE ENGINEERING & SERVICE GROUP INC.**

www.liftsafeinspections.com T. (519) 896-2430/1-800-977-2005,  
Email: info@liftsafeinspections.com F. (519) 896-2085

Customer & Location:

Project:

Date:

Description: **12 STEP ENGINE ACCESS STAND**

Date:

SIZE SCALE: N.T.S

Date: 01/28/2019

B SHEET 1 OF 1

DWG NO:

**DF071554-07-12**

REV

0