

SIGNATURE	DATE
-----------	------

REVISION HISTORY			
REV	DESCRIPTION	DATE	APPROVED
6.1	ISSUED FOR PRODUCTION	4/7/2016	C.R.

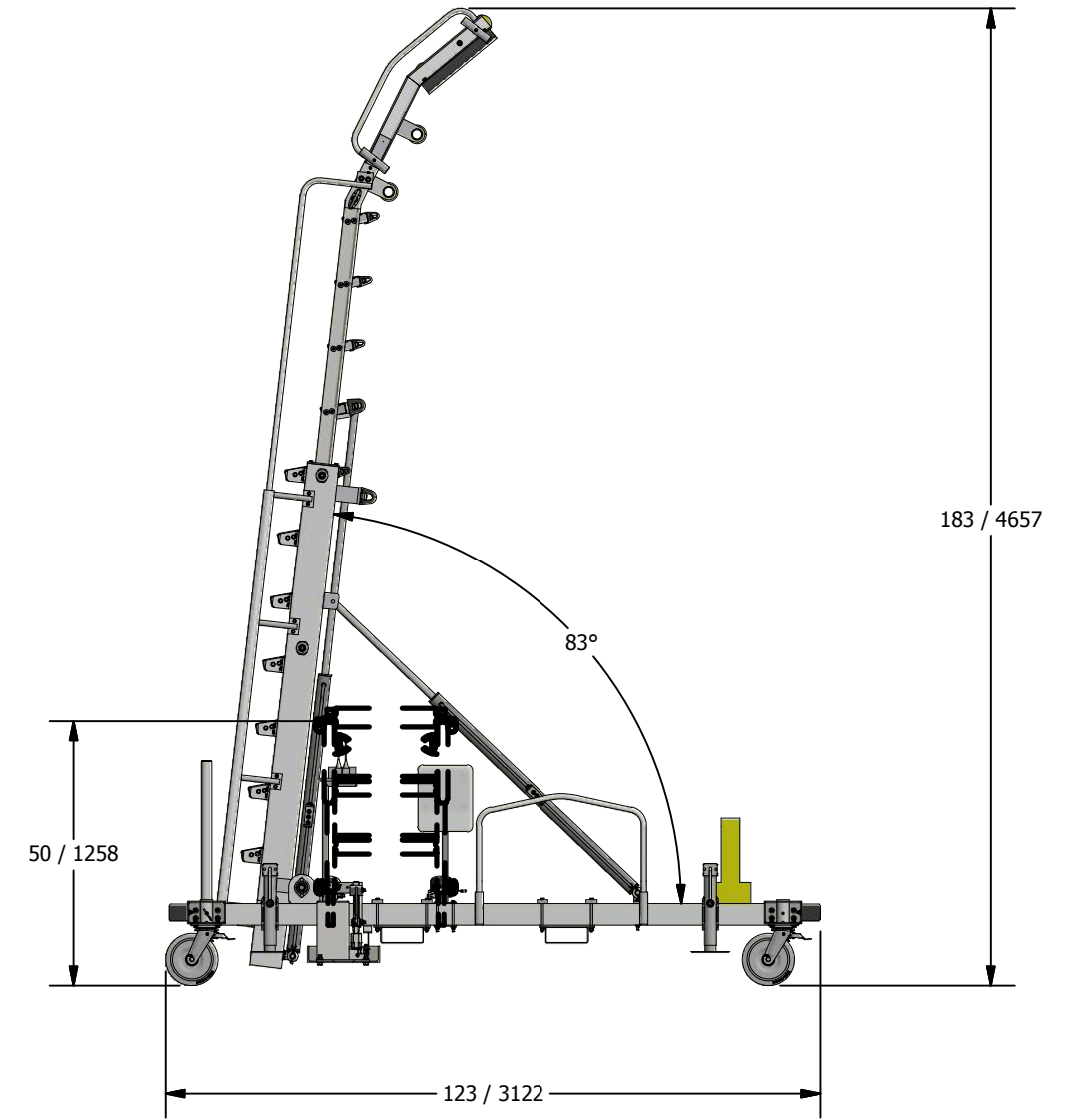
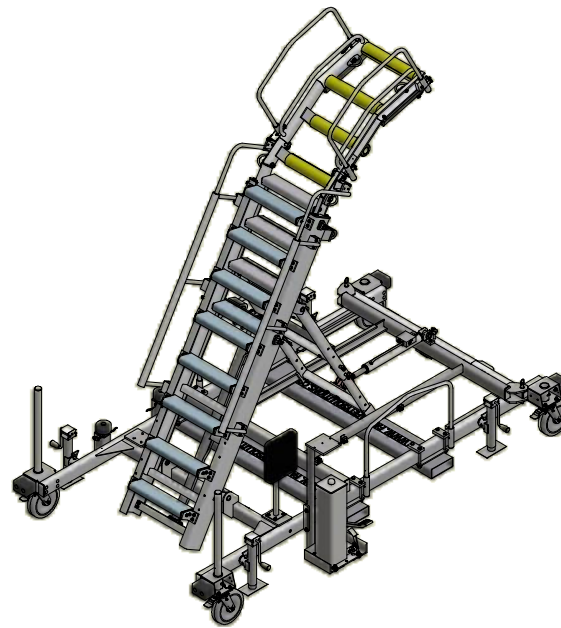
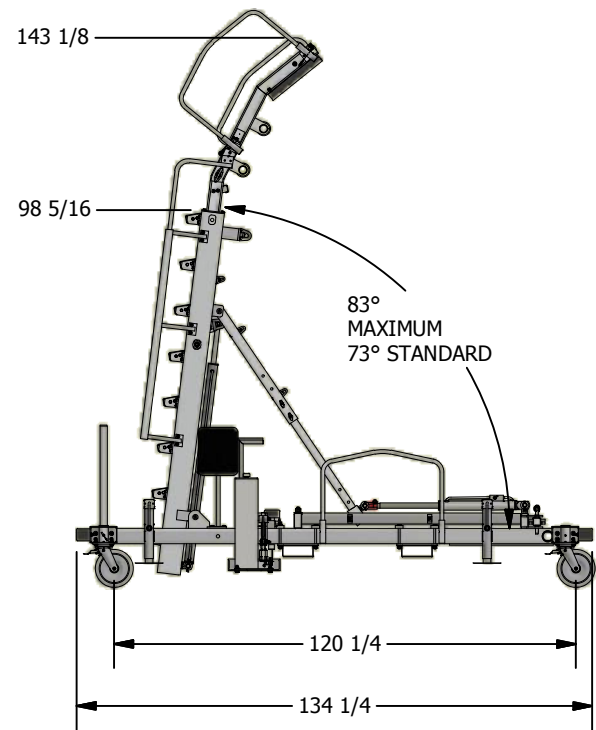
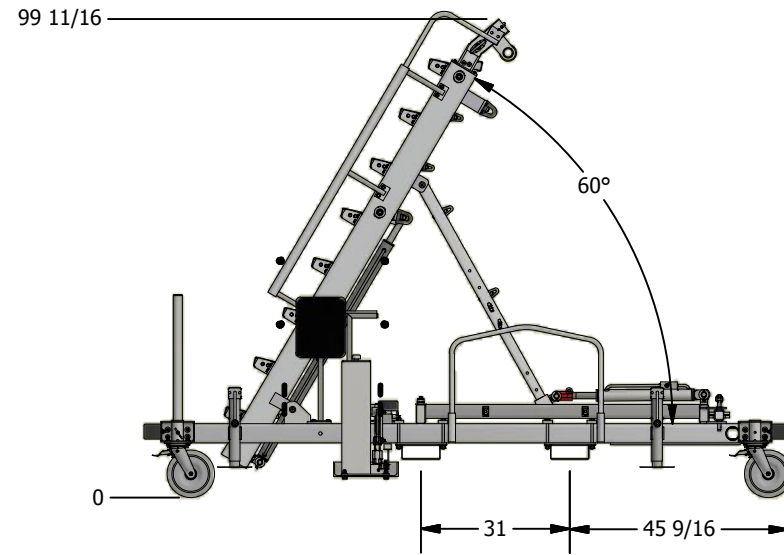
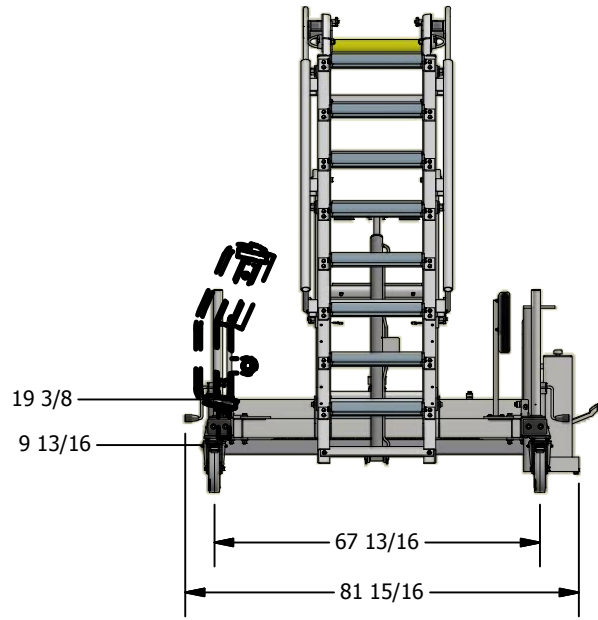

GENERAL NOTES:

- 1) ALL STRUCTURAL STEEL SECTIONS SHALL CONFORM TO CSA G40.21-50W
- 2) ALL STEEL PLATE AND BAR SHALL CONFORM TO CSA G40.21-44W
- 3) ALL WELDING SHALL CONFORM TO CSA W59 AND BE UNDERTAKEN BY A WELDER FULLY APPROVED BY THE CANADIAN WELDING BUREAU TO CSA W47 DIVISION
- 4) ALL WELDS TO BE SMOOTH AND FREE OF BURRS
- 5) ALL WELDS TO BE 1/4" CONTINUOUS FILLET OR 1/4" EFFECTIVE THROAT FLARE BEVEL U.N.O.

THIS DRAWING AND THE INTELLECTUAL INFORMATION ON THIS DRAWING ARE THE PROPERTY OF LIFTSAFE ENGINEERING & SERVICE GROUP INC. AND MAY NOT BE REPRODUCED OR USED IN ANY MANNER WITHOUT OUR WRITTEN CONSENT

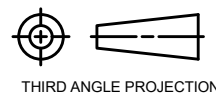

Tolerance Unless Noted Otherwise				
ANGLE	FRACTION	DECIMAL PLACES	INCHES	MILLIMETRES
± 1/2°	± 1/16	.XXX	± .005	± 0.1
		.XX	± .010	± 0.3
		.X	± .020	± 0.5

Part No. V02081	 LIFTSAFE ENGINEERING & SERVICE GROUP INC. www.liftsafeinspections.com T. (519) 896-2430/1-800-977-2005, Email: info@liftsafeinspections.com F. (519) 896-2085	
Materials. -----		
Work Order No.	Customer & Location:	
Next Assembly.	Project: ENG. ACCESS STAND	
Checked By: CR	Date: 4/7/2016	Description:
Designed By: GR	Date: 4/7/2016	SIZE: N.T.S
Drawn By: GR	Date: 4/7/2016	SCALE: N.T.S
		DWG NO: DF071554-07-08
		REVISION: 6.1

SHEET 1 OF 1